



SC3 – cPCI Storage Blade Operations Manual

August 2004

**Rev. A
PN 610200067**

ESD Warning



Before handling the SC3, rear transition board (RTB), or any media associated with the SC3, ensure that you are working in an ESD-safe environment. This includes wearing a wrist-strap that is connected to the cPCI chassis. Another precaution is to touch the cPCI chassis before handling or installing/removing the SC3, RTB, or media.

Notice

This manual describes the features of the Adtron SC3. Adtron reserves the right to modify, amend, or in any way change the contents and/or products described herein, at any time, without notification.

The information contained in this document is provided for reference only. Adtron Corporation does not assume any liability arising out of the application or use of the products described herein. This document may contain or reference information or products protected by copyrights or patents and does not convey any license under the patent rights of Adtron Corporation, nor the rights of others. Errors in this document may be reported in writing to the following address:

Adtron Corporation
4415 E. Cotton Center Blvd.
Suite 100
Phoenix, AZ 85040
Tel: 602-735-0300, Europe +41-56-496-5640
Fax: 602-735-0359, Europe +41-56-496-5648
www.adtron.com



Adtron Corporation is an ISO 9001:2000 certified company.

Adtron logo is a trademark of Adtron Corporation.
All other names mentioned are trademarks, registered trademarks, or service marks of their respective companies.

©2002-2004 Adtron Corporation. All rights reserved.

Table of Contents

Introduction	1
SC3 Features	2
Related Documents	2
Configurations	2
SC3 Configuration 01	3
SC3 Configuration 02	3
SC3 Configuration 03	4
Jumper Settings	5
Jumper Locations	5
Setting the SCSI ID on JP1	6
Setting SCSI Disconnects on JP1	7
SCSI Termination on JP1	7
Setting the Remote LED on JP1	7
SC3 Installation	8
Introduction	8
Inserting the SC3	8
Removing the SC3	9
Basic Operation	9
SCSI Bus Scan	9
Partitioning and Formatting	9
Operating System Installation	9
Device Drivers	9
LED Indicators	10
Glossary	11
Sales and Technical Support	12
Standard Warranty	12
Revision Control	13

Introduction

The Adtron SC3 is a 3U x 4HP PICMG[®] CompactPCI[®] (cPCI[®]) compatible member of Adtron's Managed Reliability Technology[™] family of storage systems. The Adtron SC3 product family meets application specific reliability and investment targets by integrating either flash or hard disk media as a SCSI mass storage subsystem on a single slot cPCI 3U plug-in card. The available models include: SC3F (fixed solid-state flash) and the SC3H (fixed hard disk drive). Adtron's SC3 contains a built-in PCI-to-SCSI controller, along with SCSI BIOS ROM, eliminating the need for an additional system controller board. The SC3 single slot design replaces external drive enclosures, power supplies and cabling. This provides SCSI bus access for other system peripherals through an optional J2 connector. These options allow a range of applications for the SC3 including, rugged field computers, network routers, military computer systems, medical instrumentation, aviation and vehicle based computers and hardened industrial control systems.

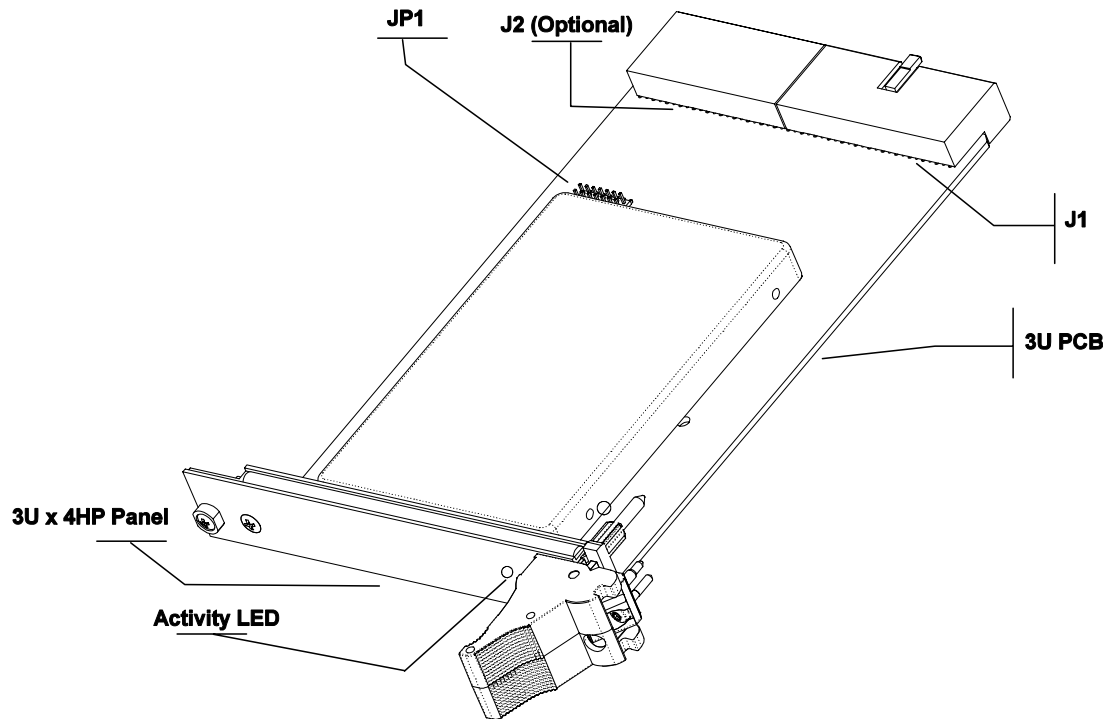

Figure 1 SC3

SC3 Features

- 33MHz, 32-bit PCI bus interface
- On-board bootable SCSI host adapter using 53C875 SCSI controller and 256 KBytes BIOS flash ROM
- CompactPCI specification PICMG 2.0 R3.0 compliant
- Compatible with the drivers found in almost every computer system
- Compliant with ANSI X3 131-1994 (American National Standard for Information Systems, SCSI-2)
- Field upgradeable firmware prevents future obsolescence
- Choice of flash or hard disk media
- 3.3V/5V PCI interface
- Flash media available in enhanced, commercial and industrial operating temperature ranges

Related Documents

- PICMG 2.0 R3.0 CompactPCI Specification
- SYM53C875 Symbios Logic Data Manual
- LSI Logic LSI53C875 Data Manual
- AMD #1734B AMD AM53CF94/96 SCSI Controller Data Sheet
- ANSI X3.131-1994 SCSI Interface Document

The Adtron SCSI command set is beyond the scope of this document. For a detailed description of the supported commands, refer to:

- Adtron SCSI Command Set OEM Manual (PN: 610200044, EN: J15047)
- SC3 Product Specification

Configurations

The SC3F (flash) and SC3H (hard disk drive) consist of three configurations:

Configuration	SCSI Controller	J2 (Rear I/O)
01	Populated	Not required.
02	Not populated	SCSI In - Required.
03	Populated	SCSI Out - Required.

Table 1 Configurations

SC3 Configuration 01

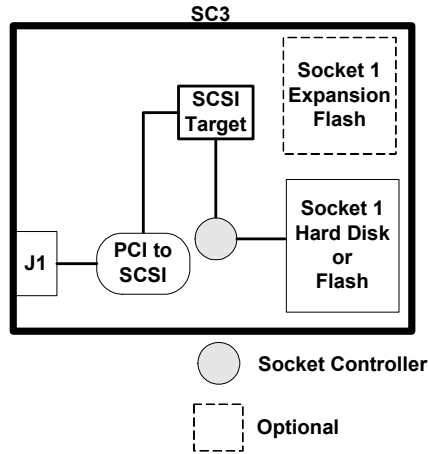

Figure 2 shows configuration 01. The SC3 is a self-contained unit with a SCSI target controller. A SCSI host controller, PCI-to-SCSI, interfaces with J1 to read and write data from the cPCI bus. No RTB or cables are required for configuration 01.

Figure 2 Configuration 01

SC3 Configuration 02

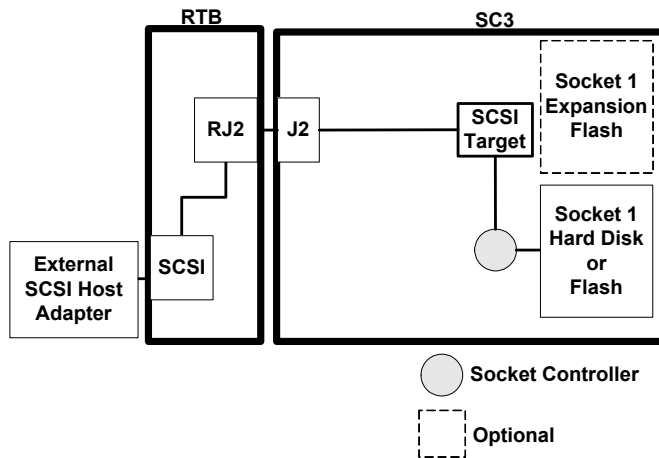

Figure 3 shows configuration 02. The on-board SCSI controller is a target controller and the SCSI host controller is external to the SC3, brought into J2 on the SC3 through either an RTB or other cabling methods¹. A PCI-to-SCSI controller is not populated. Cables for external SCSI connections are not supplied.

Figure 3 Configuration 02

Note 1: The above figure is a conceptual representation. Contact Adtron Sales for more information if an RTB is required.

SC3 Configuration 03

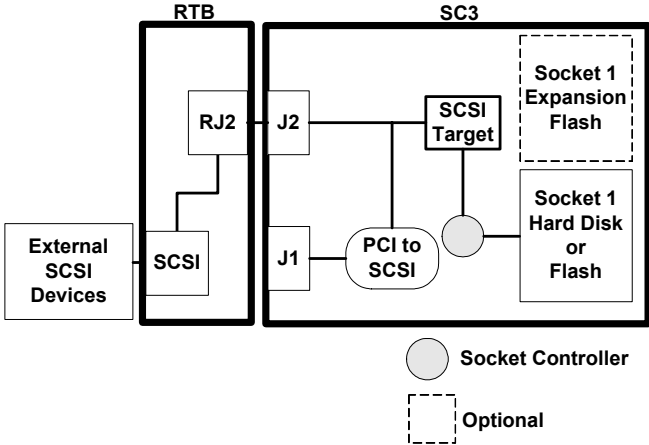

Figure 4 Configuration 03

Figure 4 shows configuration 03. The SC3 operates as the SCSI host for the disk or flash drives and can also act as the SCSI host for external SCSI devices connected through J2 on the RTB¹. Data is transferred over the cPCI bus through J1 on the SC3. Cables for external SCSI connections are not supplied.

Note 1: The above figure is a conceptual representation. Contact Adtron Sales for more information if an RTB is required.

Jumper Settings

Jumper Locations

The SC3 has several jumper options that affect various operations. Before the SC3 is installed and powered, the jumpers should be set according to your configuration and needs. Refer to Figure 5 for the location of the jumpers on the SC3.



Static Sensitive - The SC3 is a static sensitive device. While setting jumpers, take precautions to ensure that static does not discharge into or through the SC3.

The following figure shows the jumper location on the SC3.

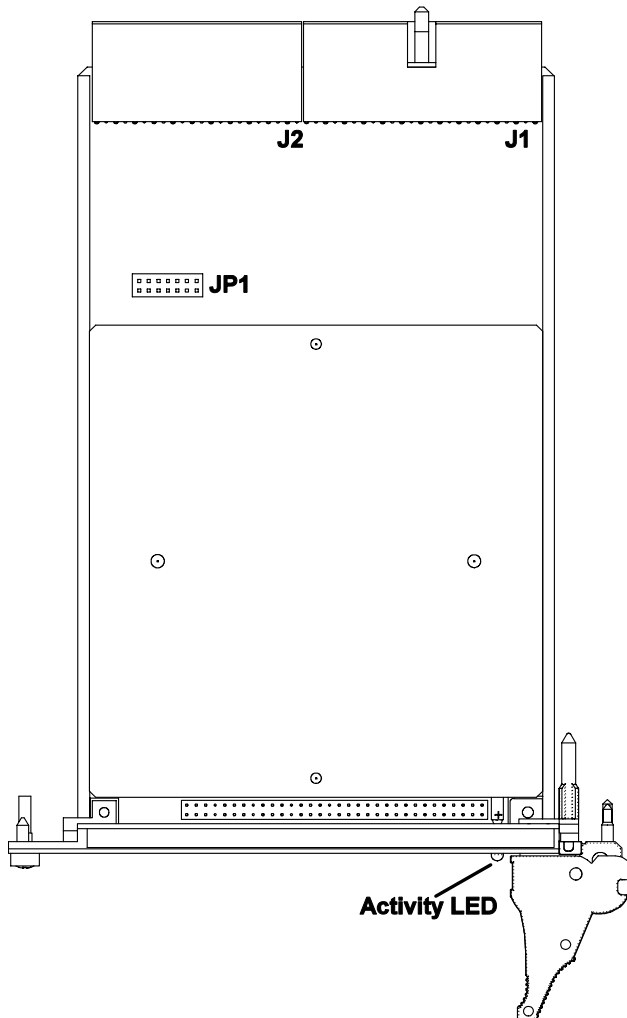
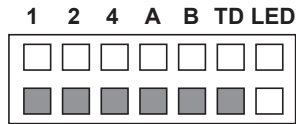

Figure 5 SC3 Jumper Location

Setting the SCSI ID on JP1

Set the SCSI ID before installing the SC3 in the cPCI chassis. JP1 is a set of option jumpers used to configure the internal SCSI ID, internal SCSI termination, options, and to power an external LED. The grayed pins are signal ground.



JP1

The pin labeled "A" is reserved for future options and is currently not used.

Figure 6 JP1 Jumpers

The default internal SCSI ID for the SC3 is 0. See Table 2 for valid SCSI IDs.

SCSI ID	JP1 Pin "4"	JP1 Pin "2"	JP1 Pin "1"
0	OFF	OFF	OFF
1	OFF	OFF	ON
2	OFF	ON	OFF
3	OFF	ON	ON
4	ON	OFF	OFF
5	ON	OFF	ON
6	ON	ON	OFF
7	ON	ON	ON

Table 2 SCSI IDs

The SCSI ID is set by using the pins labeled "1", "2", and "4" on JP1. To change the SCSI ID, install or remove jumpers according to Table 2.



Any change to the SCSI ID during operation requires a power cycle.

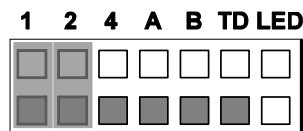

JP1

In Figure 7, pins 1 and 2 are connected to ground (low) for SCSI ID 3.

Figure 7 JP1 Jumper - SCSI ID 3 Example

Setting SCSI Disconnects on JP1

SCSI disconnects are controlled by the SCSI host adapter. Disconnects are enabled by default on this product. Without using the host adapter controls, disconnects can be disabled by installing a jumper on pin labeled "B" on JP1.

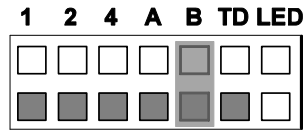

JP1

Figure 8 JP1 Jumper – Pin B

SCSI Termination on JP1

The SC3 has built-in SCSI Termination that is powered from the system. The jumper in Figure 9 controls the internal SCSI Termination for the SC3. SCSI Termination is enabled by default. Installing a jumper on pin labeled "TD" disables SCSI Termination. This jumper should only be installed if the SC3 is not at the end of the SCSI bus.

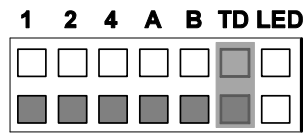

JP1

Figure 9 JP1 Jumper - Pin TD

Setting the Remote LED on JP1

The jumper shown in Figure 10 is used to install a remote-mounted LED. The output is active-low. An LED can be installed directly across both pins or connected to the pin from the inverter and powered externally (components shown are built into the SC3).

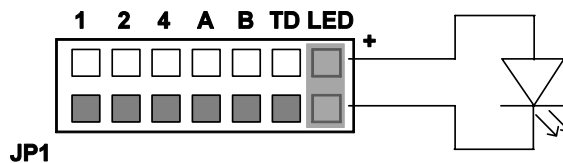

JP1

Figure 10 JP1 Jumper – Remote LED

SC3 Installation

Introduction

The SC3 is a 3U cPCI device and should be installed in a compatible cPCI chassis. The SC3 is a universal peripheral that operates in either 5V or 3.3V PCI signaling environments. The SC3 does not require a Coding Key.

Signaling	Color
3.3V	Cadmium Yellow
5V	Brilliant Blue
Universal	None

Table 3 Color codes

Before installing the SC3, make sure that guide rails are installed in the chassis. Also, do not force the SC3 if there is any mechanical resistance. Check the alignment of the guide rails and for any obstructions.



Static Sensitive - The SC3 is a static sensitive device. When installing and uninstalling the SC3 in the chassis, take precautions to ensure that static does not discharge into or through the SC3.

Inserting the SC3

To install the SC3 in your chassis:

1. Turn the system power off.
 2. Locate an empty 3U peripheral slot. (Not the system slot with red guide rails.)
 3. Remove the slot cover plate, if present.
 4. Unlatch the handle on the SC3 by pressing in on the release button on the handle.
 5. Holding the SC3 by the handle with J1 at the bottom, properly align the SC3 with the guide rails and slide it back until it touches the backplane connectors.
 6. To engage the handle, simultaneously push the SC3 into the backplane while levering in on the handle until the handle locks into the chassis.
 7. Fasten the screw located inside the handle of the chassis, if desired.
-



Removing the SC3

To remove the SC3 from your chassis:

1. Turn the system power off.
 2. Unscrew the screw located inside the handle.
 3. Unlatch the handle by pressing in on the release button while levering out on the handle until the SC3 disengages from the backplane.
 4. Holding the SC3 by the handle, slide the SC3 out of the chassis.
-



Basic Operation

The SC3 operates as a storage subsystem on the SCSI bus that can be used as a boot device or as additional storage.

SCSI Bus Scan

After power-up, use the system facilities to perform a bus scan and verify that the SC3 shows up. If it does not show up, check the seating of the SC3. Also, check the SCSI cable connection, termination, and SCSI ID settings.

Partitioning and Formatting

The SC3 disk drives are shipped unformatted. To the operating system, the SC3 looks like a single disk drive. Use the operating system utilities to partition and/or format the SC3.

Operating System Installation

Many popular operating systems may be used with the SC3. Consult the operating system documentation for more information on installation and support.

Device Drivers

The SC3 uses a widely supported SCSI controller and should operate in most modern operating systems. However, the SC3 may require device drivers for certain operating systems.

Visit the LSI web site at www.lsilogic.com for device drivers for the LSI 52C875 SCSI bus controller chip

LED Indicators

The LED located on the front panel is used to indicate media activity. The table below shows the different bank states and the respective LED states.



Figure 11 SC3 LED

Activity LED (Green)	Description
OFF	No accesses
GREEN	Reads/Writes occurring

Table 4 LED Indicators

Glossary

BIOS	Basic Input/Output System, BIOS is a chip located on all computer motherboards that contains instructions and setup for how your system should boot and how it operates.
cPCI	Compact Peripheral Component Interconnect
Hard Disk	A rigid magnetic disk fixed permanently within a drive unit and used for storing computer data.
Flash	Flash memory is non-volatile memory that is an integrated circuit that does not need continuous power to retain the data.
LED	Light-Emitting Diode, LED is a special type of semiconductor that illuminates when an electrical charge passes through it.
PCB	Printed Circuit Board, PCB is a board made of plastic or fiberglass designed to hold electronic circuits, IC's, switches and other components.
PCI	Peripheral Component Interconnect
RTB	Rear Transition Board
SCSI	Small Computer System Interface
SCSI Bus	The electric circuits used to connect the SCSI device to the SCSI controller that communicates with the computer.

Sales and Technical Support

Contact Adtron Corporation for technical support, application questions, data sheets, and documentation. Our normal business hours are Monday through Friday, 8am to 5pm, MST.

Headquarters – Sales

Adtron Corporation
4415 E. Cotton Center Blvd.
Suite 100
Phoenix, AZ 85040
Tel: 602-735-0300
Fax: 602-735-0359
Web: <http://www.adtron.com>
Email: sales@adtron.com

Europe - Sales

Erlenweg 34
CH-5608 Stetten
Switzerland
Tel: +41-56-496-5640
Fax: +41-56-496-5648
Email: europe@adtron.com

United States – Technical Support

Tel: 602-735-0300
Fax: 602-735-0359
Email: techsupport@adtron.com

Europe – Technical Support

Tel: +45-4557-0754
Fax: +45-4557-0753
Email: eurotech@adtron.com

Web Site

Web: <http://www.adtron.com/tech.html>

Standard Warranty

Adtron warrants this product to be free from defects in materials and workmanship for a standard warranty period of three years. If this product fails within the warranty period due to such defect, Adtron will repair or replace this product at no charge.

This warranty does not apply if this product has been damaged by abuse, accident, disaster, misuse or incorrect installation.

Revision Control

REV	Author	Date	Sections	Description
O	PAS	25 APR 2003		Original
001	JMH	16 JAN 2004	All	Update documentation
002	JMH	8 APR 2004		Final Reviews
A	JMH	12 JUL 2004	Install-fields, Basic operations	ECN Review