

XceedSecure2 2.5" PATA Installation Manual

Introduction

The XceedSecure2 2.5" PATA drive with the ArrayPro® performance engine supports flash storage in an industry-standard, 2.5-inch form factor and is a drop-in replacement for standard rotating hard disk drives. This document provides instructions for installing the XceedSecure2 2.5" PATA drive.

ESD Caution

 Static electricity may be discharged through the XceedSecure2 2.5" PATA drive. In extreme cases, this may temporarily interrupt the operation or damage components. Touch a grounded device, such as a computer case, prior to handling the XceedSecure2 2.5" PATA drive.

Pre-Installation

Before beginning the installation, turn OFF the computer power and make sure you are properly grounded. The XceedSecure2 2.5" PATA drive metal casing is isolated and is not tied to DC (signal) ground.

J1 and JP1

The XceedSecure2 2.5" PATA drive contains two jumper areas: J1 and JP1. The J1 pins are used for configuring the master/slave settings. The JP1 pins provide options for setting data transfer modes and enabling Write Protect. See [Figure 1](#) and [Figure 2](#) for locations and settings.

Make sure you identify the cable connection option (see [Secure Erase External Trigger](#) below) before setting the J1 jumper.

Master/Slave Setting (J1)

The XceedSecure2 2.5" PATA drive is set to master by default. To change the setting to slave or cable select, place a jumper on the appropriate J1 pins. See [Figure 1](#) for jumper settings and [Table 5](#) for the associated IDE signals.

Data Transfer Mode Setting (JP1)

By default, the XceedSecure2 2.5" PATA drive is set for UDMA and Multiword DMA transfer modes. To disable DMA modes, place a jumper across JP1 pins 2 and 3 (see [Figure 2](#)). The XceedSecure2 2.5" PATA drive also supports PIO modes, which are always enabled.

Write Protect Setting (JP1)

The Write Protect feature is disabled by default. To enable Write Protect, place a jumper across JP1 pins 1 and 2 (see [Figure 2](#)).

Indicators	One bi-colored (orange/green) LED
Interface	PATA interface
Size	69.9 mm [2.75"] W x 101.6 mm [4.00"] D x 9.5 mm [.375"] H
Weight	Based on capacity
Power	5 V +/- 5% @ 1.25 A (max) (based on capacity)

Table 1: Specifications

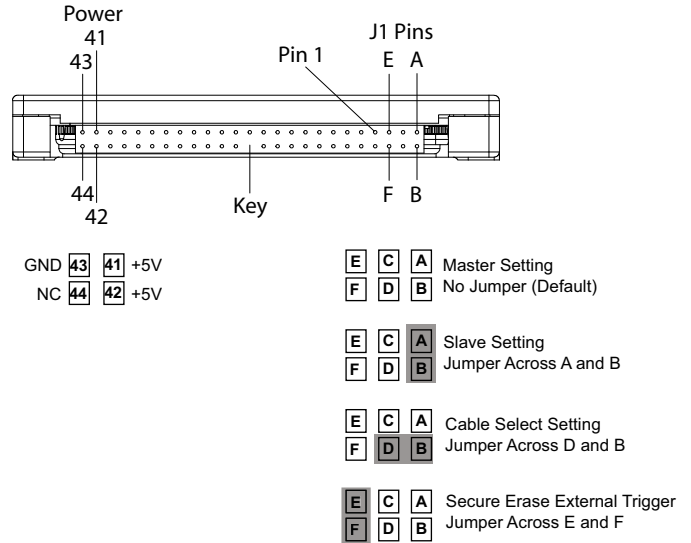

Figure 1. J1 Location and Settings

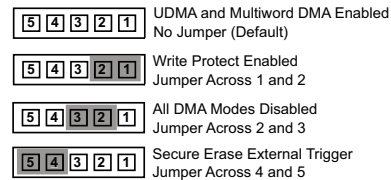
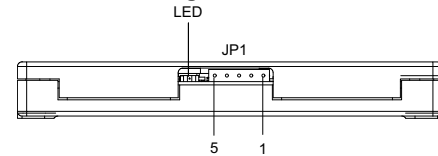

Figure 2. JP1 Location and Settings

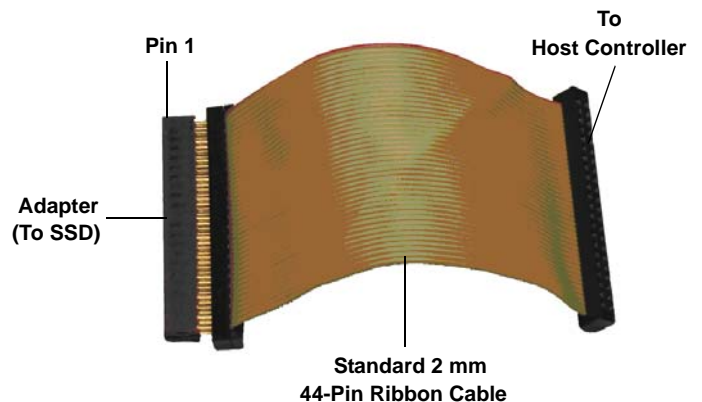

Figure 3. 2 mm Square Tail Socket (Adapter)

Secure Erase External Trigger

The XceedSecure2 contains pins for a secure erase external trigger at both jumper locations. Shorting pins 4 and 5 on JP1 triggers the secure erase operation (see Figure 2). If using J1, provide a minimum of 10 mA at +3.0 V to +40 V through pin E and a return on pin F (see Figure 1). To use the external trigger, you must enable the feature, as described in the *Adtron EraSure® Programmer's Guide*. Please contact Adtron Sales or Technical Support to request this guide for a complete reference of operations and methods.

Connecting the Cable

Pins 41 and 42 on the XceedSecure2 2.5" PATA drive receive +5 V power from the cable (see Figure 1 for the location of the pins). Pin 43 is ground, and pin 44 is not connected. The XceedSecure2 2.5" PATA drive does not require 12 V power.

Because the J1 pins essentially create a 50-pin configuration with the cable pins, standard 44-pin cables do not fit properly. Options for installing the SSD include using any of the following (see Table 4 on page 4 for purchasing information):

- 44-Pin Cable with 2 mm Square Tail Socket
- 50-Pin IDE Cable
- 44-to-50-Pin IDE Cable
- 50-Pin Backplane Connector
- 3.5" IDE Cable with 2.5-to-3.5 Drive Cable Adapter Converter

Each of these options is described in the following sections.

Using a 2 mm Square Tail Socket

The 2 mm square tail socket is a straight, pin-to-pin connector that reduces the overall connector width (see Figure 3). This adapter supports the use of jumper straps on pins A-F (see Figure 1). Because the 44-pin adapter is keyless, it is important to note the location of pin 1. Ribbon cable pin 1 (typically red striped) must connect to pin 1 on the SSD. See Table 5 on page 4 for the SSD pinout.

Using a 50-Pin Cable

The SSD also supports a standard 50-pin cable. When using the 50-pin cable, pin 1 on the cable connects to pin A on the SSD, and pin 50 connects to pin 44 (see Figure 4). The SSD boots as a master drive whenever a 50-pin cable is used.

Using a 2.5"-to-3.5" Drive Adapter

If the computer uses a 3.5" drive IDE cable, you must use an adapter to connect the SSD. This adapter converts the 44-pin configuration of the 2.5" form factor to a 40-pin configuration (see Figure 5). This configuration supports the use of jumper straps on pins A-F (see Figure 1 on page 1).

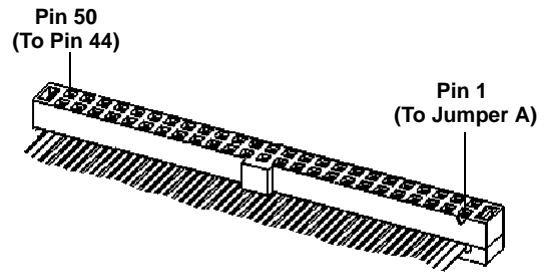

Figure 4. 50-Pin Cable Layout

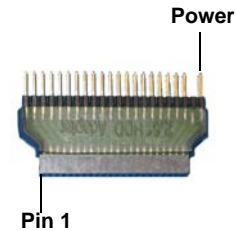

Figure 5. 3.5" Drive Cable Adapter



Figure 6. 50-Pin Backplane Connection

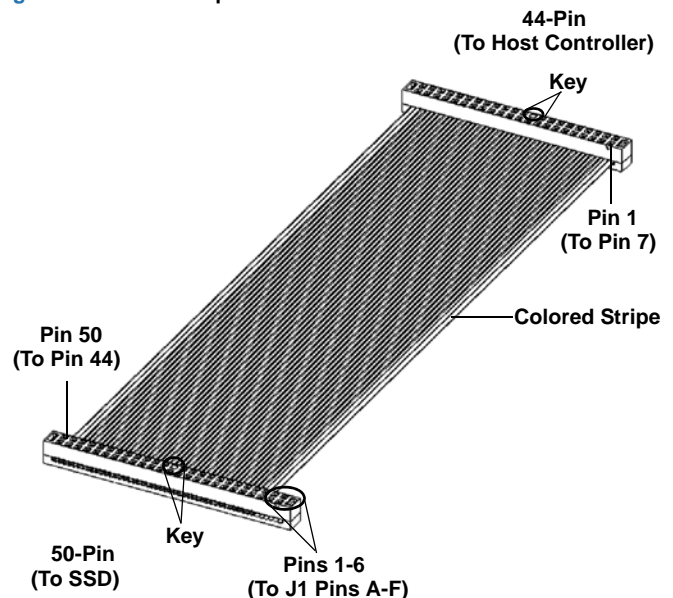

Figure 7. 44-Pin-to-50-Pin Cable

Connecting to the Backplane

You can install the SSD on any computer that uses a 50-pin backplane connector. As with connecting to a standard 50-pin cable, pin A connects to pin 1 on the backplane, and pin 44 connects to pin 50. When inserting the drive, face the label up so that pins A-F on the SSD line up with pins 1-6 on the backplane connector, as shown in [Figure 6](#). When using this configuration, set jumpers A-F on the printed circuit board (PCB). Otherwise, the SSD boots as the master drive.

Using a 44-to-50-Pin Cable

The 44-to-50-pin cable is a specialized cable that has a 50-pin connector at one end and a 44-pin connector at the other end. As shown in [Figure 7](#), the first six pins of the 50-pin connector are not physically connected to the cable. These pins connect to the jumper pins (A-F) on the SSD. With this configuration, the SSD boots as the master drive. See [Table 4](#) for a list of recommended parts used for creating a custom cable.

LED Indicators

The XceedSecure2 2.5" PATA drive uses a bi-colored (green/orange) onboard LED to indicate status. This LED is located next to JP1 on the non-host side of the drive. When power is first applied, the LED flashes green-orange while the XceedSecure2 PATA drive performs a self-test. After the self-test, the LED remains green unless the host is accessing the drive or an error condition is encountered (see [Figure 2](#) and [Table 2](#)).

Installing the XceedSecure2 2.5" PATA Drive

The XceedSecure2 2.5" PATA drive mounts into a standard 2.5" hard disk drive bay and is mountable from the side or the bottom. Before securing the drive, consider the length of the provided screws (M3 x 0.5 x 4 mm) and the thickness of the mounting surface. DO NOT exceed the maximum insertion depth of 3mm [0.118"] from the drive edge (see [Figure 8](#)) or exceed the maximum torque of 3.5 to 5.8 kg-cm [3.0 to 5.0 lb-in].

Installing an Operating System

You can use a disk formatting and partitioning utility to format the XceedSecure2 2.5" PATA drive like any standard hard disk drive. Once formatted, you can install any operating system that is compatible with IDE devices. Because the method for installing a specific operating system may vary, it is recommended you consult the operating system or IDE controller documentation for instructions.

Troubleshooting

[Table 3](#) lists some common problems and possible solutions. For more information, visit the Adtron Web site at www.adtron.com/support, send an e-mail to techsupport@adtron.com, or contact technical support at 602-735-0300 in the U.S.

LED	Indicates
Solid green	Power is ON.
Orange	The host is accessing the drive.
Flashing in a pattern	A secure erase operation is in progress, the host does not recognize the drive, or an error occurred.

Table 2: LED Indicators

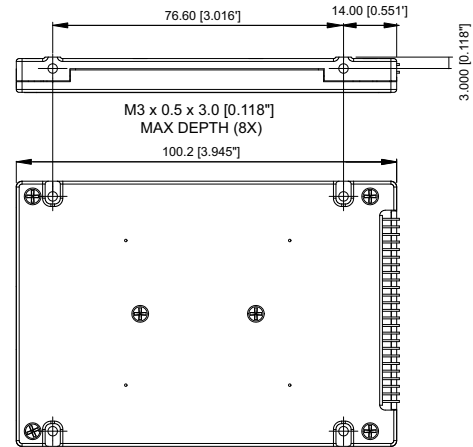

Figure 8. Mounting Holes

Problem	Possible Solution
The host computer does not recognize the XceedSecure2 2.5" PATA.	Make sure the IDE cables are seated and in good condition. Check the system BIOS settings for IDE devices. See the manufacturer's manual for information on BIOS settings.
The computer recognizes one drive, but not the other.	Check the master/slave jumper settings on both drives. One drive must be the master, and the other must be the slave.
When I turn on the computer, the XceedSecure2 2.5" PATA LED blinks in a definite pattern.	The XceedSecure2 PATA drive has detected an internal problem. Note the blinking LED pattern and color. Then contact Adtron Technical Support with BIOS, system board, and operating system information.

Table 3: Troubleshooting

Part No.	Description	Manufacturer	Website(s)
0875685063	50-Pin, 2 mm Connector	Molex	www.molex.com
0022552442	44-Pin, 2.54 mm Connector		
SQT-122-01-F-D-20	2 mm Square Tail Socket w/Gold Flash on Contact	Samtec	www.samtec.com
SQT-122-01-L-D-20	2 mm Square Tail Socket w/Gold on Contact		
ADP-IDE23	2.5" Drive to 3.5" Drive Cable Adapter Converter	Kinamax	www.Directron.com
3625/50	50-Pin Flat Ribbon Cable	3M	www.3M.com www.digikey.com
3625/44	50-Pin Flat Ribbon Cable		
150250-5222-RB	50-Pin Boardplane Connector		

Table 4: Cable Distributors

Warranty

Adtron warrants this product to be free from defects in materials and workmanship for the duration of the warranty period. If this product fails within the warranty period due to such a defect, Adtron will repair or replace this product.

This warranty does not apply if this product has been damaged by abuse, accident, disaster, misuse, or incorrect installation. There are no user-serviceable components within the XceedSecure2 2.5" PATA drive.

Notice

This manual describes the features of the XceedSecure2 2.5" PATA drive. Adtron reserves the right to modify, amend, or in any way change the contents and/or products described herein, at any time, without notification.

The information contained in this document is provided for reference only. Adtron Corporation does not assume any liability arising out of the application or use of the products described herein. This document may contain or reference information or products protected by copyrights or patents and does not convey any license under the patent rights of Adtron Corporation, nor the rights of others.

Pin	Signal	Pin	Signal
A	J_-Slave	B	JP_B
C	JP_C	D	J_CSEL_-EN
E	JP_E	F	JP_F
1	-RESET	2	GND
3	DB7	4	DB8
5	DB6	6	DB9
7	DB5	8	DB10
9	DB4	10	DB11
11	DB3	12	DB12
13	DB2	14	DB13
15	DB1	16	DB14
17	DB0	18	DB15
19	GND	20	[KEY]
21	DMARQ	22	GND
23	-DIOW	24	GND
25	-DIOR	26	GND
27	IORDY	28	CSEL
29	-DMACK	30	GND
31	INTRQ	31	-IOCS16
33	DA1	32	-PDIAG
35	DA0	34	DA2
37	-CS0	36	-CS1
39	-DASP	38	GND
41	+5V	40	+5v
43	GND	44	N/C

Table 5: Signal Pinout

