

XceedSecure2 SCSI Installation Manual

Introduction

The XceedSecure2 SCSI flash drives offer durable flash storage in an industry-standard 3.5" form factor and are RoHS-compliant. Available in 68-pin or 80-pin configurations, these drives provide a drop-in replacement for rotating hard disk drives. This document provides instructions for installing the XceedSecure2 SCSI drive in a host system.

ESD Caution



Static electricity may be discharged through the drive. In extreme cases, this may temporarily interrupt the drive operation or damage components. Touch a grounded device, such as a computer case, prior to handling the drive.

Pre-Installation

Before beginning the installation, turn OFF the computer power and make sure you are properly grounded.

Jumper Sets

Both the 68-pin and 80-pin drives contain two jumper areas on the non-host side (J1 and J2). The 68-pin drives also include a 12-pin jumper area (JP1). These pins are used for setting the SCSI ID, write protect, and other functions. See Figure 1 and Figure 2 for locations and settings.

SCSI Termination

Because the XceedSecure2 SCSI drive does not contain on-board termination circuits, Adtron recommends properly terminating each end of the bus in accordance with the SCSI Parallel Interface (SPI) specification.

SCSI ID

Jumpers on pins 1-8 of J1 and JP1 determine the SCSI ID (no jumpers indicate ID 0). Refer to the Figure 6 for the jumper settings.

Write Protect

By default, Write Protect is disabled. To enable Write Protect, place a jumper across pins 11 and 12 on J1 or pins 9 and 10 on JP1.

Parity

The XceedSecure2 SCSI SSD uses a parity bit to check for data errors. By default, parity checking is enabled. To disable parity, place a jumper across pins 13 and 14 on J1.

Indicators	Three LEDs (two green and one orange)
Interface	SCSI-3 interface
Size	101.7 mm [4.0"] W x 147.0 mm [5.8"] D x 25.5 mm [1.0"] H (max)
Weight	518.0 g [1.1 lbs] for 128 GByte drive (typ)
Power	5 V +/- 5% @ 2.5 A (max)

Table 1: Specifications

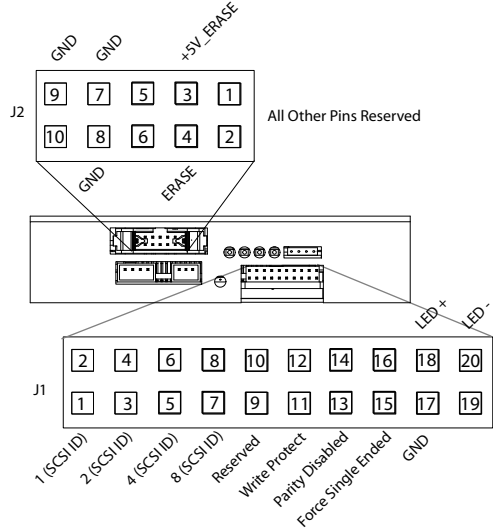

Figure 1: J1 and J2 Locations and Settings

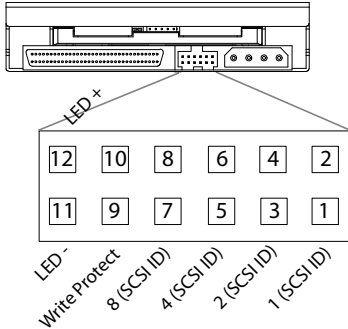

Figure 2: JP1 Location and Settings (68-Pin Drives Only)

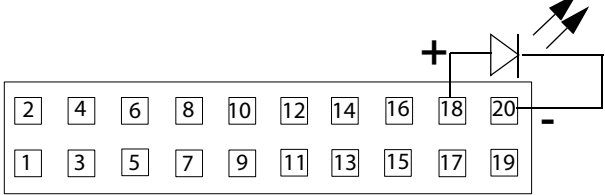

Figure 3: J1 Remote LED Connection

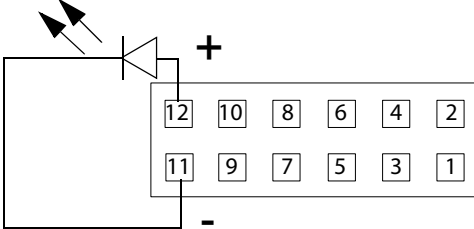

Figure 4: JP1 Remote LED Connection (68-Pin Drives Only)

Single-Ended (SE) and Low Voltage Differential (LVD)

All SCSI buses require a termination network at each end to function properly. Bus termination differs depending on the type of SCSI devices present on the bus, such as SE or LVD devices. The XceedSecure2 SCSI supports multi-mode active termination applications with SE and LVD SCSI devices on the same bus. The SCSI bus DIFFSENS signal determines the appropriate termination.

Placing a jumper across J1 pins 15 and 16 forces the XceedSecure2 SCSI SSD drive to operate in SE mode only. If left open, the drive operates as either SE or LVD, depending on the configuration mode. All configuration modes comply with the Small Computer System Interface-3 (SCSI-3) specification.

Remote LED

J1 pins 18 and 20 and JP1 Pins 11 and 12 support the connection of a remote light emitting diode (LED). The output is active high and includes on-board, current-limiting resistance of 200 ohms.

To install the LED on J1, connect the positive lead to pin 18 and the negative to pin 20 (see Figure 3). To install the LED on JP1, connect the positive lead to pin 12 and the negative to pin 11 (see Figure 4). When installed, the LED indicates drive activity.

Secure Erase Hardware Trigger

The XceedSecure2 SCSI drives support EraSure®, offering multiple levels of data elimination sequences. Using vendor-specific commands, the host system can initiate one of several secure erase operations, including IRIG 106-07, Clear, and custom sequences (see the *EraSure Programmer's Guide* for more information).

The drive also supports the initiation of secure erase operations through pins on J2 (see Figure 1). To configure a trigger with the cable, make sure the feature is enabled, then either apply current directly to the ERASE pin (pin 4) or install a switch.

To use secure erase operations without a switch, provide a minimum of 10 mA at +3.0 V to +40 V through pin 4 and referenced to ground on J2 (pin 7 or 8). The operation is initiated whenever the required current flows through these pins for at least 40 msecs.

If installing a switch, connect the ERASE pin (pin 4) to the 5 V pin (pin 3) to a switch (see Figure 5). When the switch is pressed for at least 40 msecs, the loop closes, initiating the secure erase operation. For information on cables and connectors, visit www.samtec.com and reference the following part numbers:

- EHT-105-01-S-D-RA - Ejector Header (connector on drive)
- TCSD-05-D-12.00-01-F-N- IDC Socket Cable (12" double-ended mating cable)

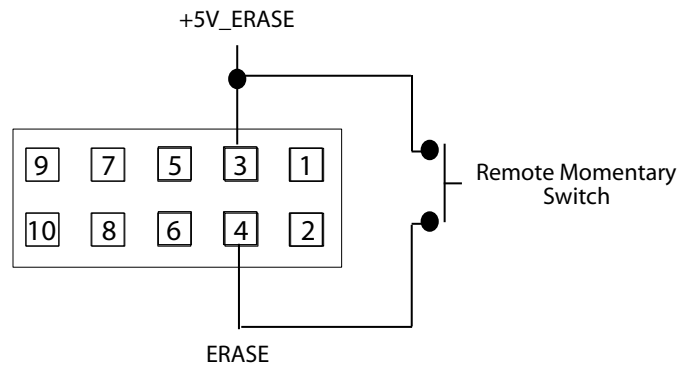

Figure 5: Secure Erase External Trigger

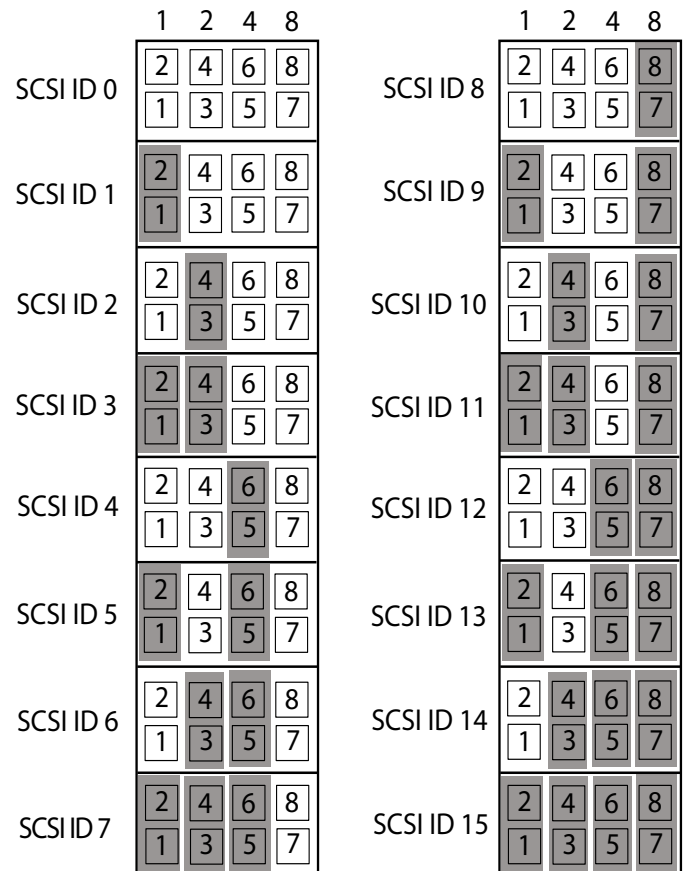

Figure 6: SCSI ID Settings

LED Indicators

The XceedSecure2 SCSI drive uses three (power, SCSI activity, and media activity), on-board LEDs to indicate drive status. These LEDs are located next to J1 and J2. The power LED (green) indicates power, and the other LEDs indicate activity: one for SCSI activity (green); and one for media activity (orange). When power is first applied, the orange media LED flashes while the XceedSecure2 drive performs a self-test. After the self-test, the orange media activity LED lights if the host is accessing the drive or if the drive encounters an error condition. The green SCSI Activity LED lights when commands and data are sent over the SCSI bus (see Figure 7 and Table 2).

LED	Indicates
Green (Power)	Power is ON.
Orange (Media Activity)	The host is accessing the drive.
Orange (Media Activity) flashing in a pattern	A secure erase operation is in progress, the host does not recognize the drive, or an error occurred.

Table 2: LED Indicators

Installation

To install the XceedSecure2 SCSI drive, slide the drive into any standard 3.5" hard disk drive bay. Before securing the drive, consider the length of the provided screws (3/16") and the thickness of the mounting surface. DO NOT exceed the maximum insertion depth of 3.80 mm [.15"] from the drive edge (see Figure 8) or exceed the maximum torque of 3.0 to 3.5 kg-cm [2.6 to 3.0 lb-in]. All standard connectors and mounting hole locations comply with the SCSI-3 Specification.

Connecting the Cables

The 68-pin XceedSecure2 SCSI drive contains a 4-pin power connection (see Table 3 for pinout information). The 80-pin drive receives power through the SCSI connection.

Installing an Operating System

You can use a disk formatting and partitioning utility to format the drive like any standard hard disk drive. Once formatted, you can install any operating system that is compatible with SCSI devices. Because the method for installing a specific operating system may vary, Adtron recommends you consult the operating system or SCSI controller documentation for instructions.

Troubleshooting

Table 4 lists some common problems and possible solutions. For more information, visit the Adtron web site at www.adtron.com/support, send an e-mail to techsupport@adtron.com, or contact technical support at 602-735-0300 in the U.S.

Warranty

Adtron warrants this product to be free from defects in materials and workmanship for the duration of the warranty period. If this product fails within the warranty period due to such a defect, Adtron will repair or replace this product.

This warranty does not apply if this product has been damaged by abuse, accident, disaster, misuse or incorrect installation. There are no user-serviceable components within the XceedSecure2 SCSI drive.

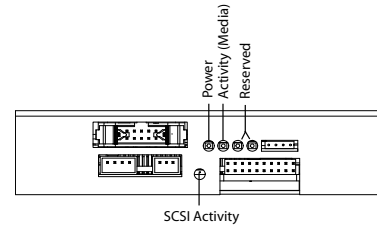

Figure 7: LED Locations

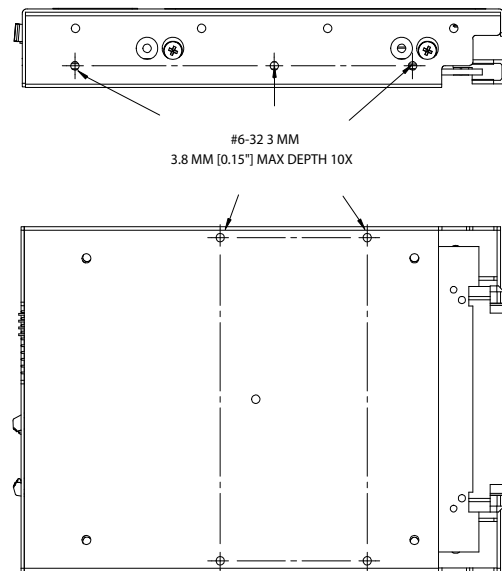

Figure 8: Mounting Hole Locations

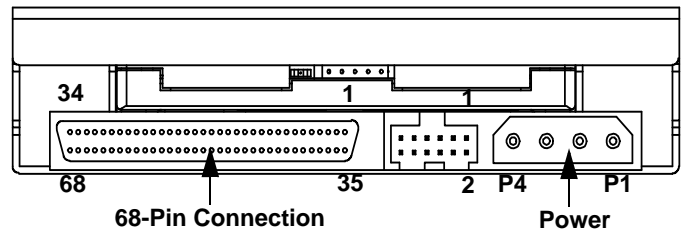

Figure 9: 68-Pin Connections

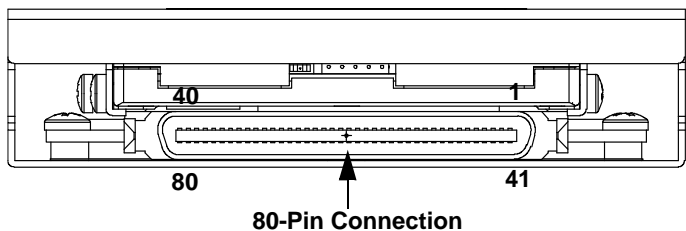

Figure 10: 80-Pin Connection

Notice

This manual describes the features of the XceedSecure2 SCSI drive. Adtron reserves the right to modify, amend, or in any way change the contents and/or products described herein, at any time, without notification.

The information contained in this document is provided for reference only. Adtron Corporation does not assume any liability arising out of the application or use of the products described herein. This document may contain or reference information or products protected by copyrights or patents and does not convey any license under the patent rights of Adtron Corporation, nor the rights of others.

Pin	Description
P1	Not Connected (12 V Not Needed)
P2	Ground
P3	Ground
P4	+5 V

Table 3: Power Pinout (68-Pin Drives Only)

Problem	Possible Solution
The SCSI bus does not recognize the drive during the boot process.	1. Make sure the SCSI ID does not conflict with other SCSI devices. 2. Check for proper SCSI termination on each cable end.
The system hangs while booting.	
The orange media LED blinks once every second after cycling power on the system.	The drive encountered an error. Contact Adtron Technical Support for assistance.
The orange media LED blinks in a specific pattern, and the drive is not performing a secure erase operation.	Cycle power on the drive or on the entire system. If this does not resolve the issue, contact Adtron Technical Support.
The drive does not report the correct SCSI ID based on the jumper settings.	Make sure to use only one location to set the SCSI ID. Because the SCSI ID pins run parallel, setting the SCSI ID at multiple locations may alter the SCSI ID. For example, if J1 is set to SCSI ID 1 and JP1 or the backplane is set to SCSI ID 2, the drive will report SCSI ID 3.

Table 4: Troubleshooting



Adtron Corporation
 4415 E. Cotton Center Blvd.
 Phoenix, AZ 85040
 Tel: U.S. 602-735-0300
 Fax: U.S. 602-735-0349
<http://www.adtron.com>