

## Xcel-10 Installation Manual

### Introduction

The Xcel-10 flash drive delivers all the advantages of solid state flash disk technology with the advances of the Serial ATA (SATA) interface in an industry-standard 2.5-inch form factor. This document provides instructions for installing the Xcel-10 in a host system.

### ESD Caution



Static electricity may be discharged through the Xcel-10 drive. In extreme cases, this may temporarily interrupt the drive operation or damage components. Touch a grounded device, such as a computer case, prior to handling the Xcel-10 drive.

### Pre-Installation

Before beginning the installation, turn OFF the computer power and make sure you are properly grounded. The Xcel-10 drive metal casing is isolated and is not tied to DC (signal) ground.

### Installing the Xcel-10

The Xcel-10 drive mounts from the side or the bottom into a standard 2.5" hard disk drive bay. Before securing the drive, consider the length of the provided screws (M3 x 0.5 x 4 mm) and the thickness of the mounting surface. DO NOT exceed the maximum insertion depth of 3 mm [0.118"] from the drive edge (see Figure 2) or exceed the maximum torque of 3.0 to 3.5 kg-cm [2.6 to 3.0 lb-in].

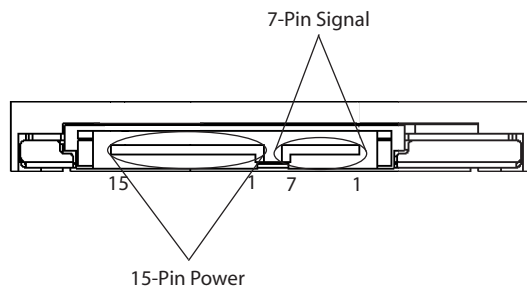

Figure 1. SATA Connections

### Connecting the Cable

Using a SATA cable, connect the Xcel-10 drive to the SATA interface. The SATA cable provides +5 V power through the 15-pin power segment as shown in Figure 2. The Xcel-10 drive does not require 3.3 V or 12 V. Refer to Tables 2 and 3 for pins and signals for the SATA interface. DO NOT fold or crease the SATA signal cable. Doing so may cause the loss of data or data errors.

<b>Interface</b>	SATA 1.5 Gbps interface
<b>Size</b>	70.0 mm [2.76"] W x 100.4 mm [3.93"] D x 9.5 mm [.374"] H (max)
<b>Weight</b>	100 g [0.22 lbs] (max)
<b>Power</b>	5 V +/- 5% @ 1.0 A – Additional power is required for hot swapping the drive (see the Product Specification)

Table 1: Specifications

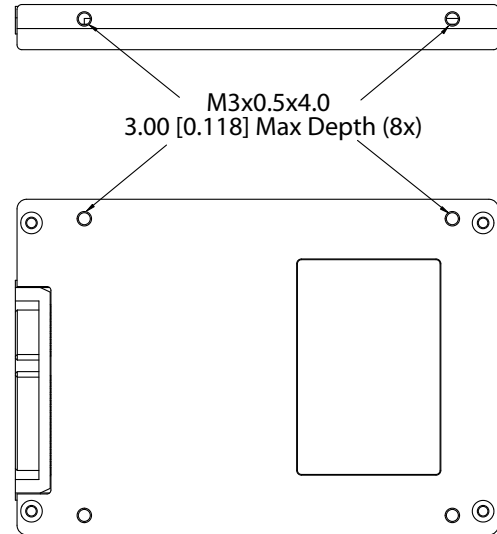

Figure 2. Mounting Holes

Pin	Signal
P1	Not Used (3.3 V)
P2	Not Used (3.3 V)
P3	Reserved (3.3 V)
P4	Reserved (GND)
P5	Ground
P6	Ground
P7	5 V
P8	5 V
P9	5 V
P10	Ground
P11	Reserved
P12	Ground
P13	Not Used (12 V)
P14	Not Used (12 V)
P15	Not Used (12 V)

Table 2: 15-Pin Power Segment

Pin	Signal
S1	Ground
S2	Dev Rx +
S3	Dev Rx -
S4	Ground
S5	Dev Tx -
S6	Dev Tx +
S7	Ground

Table 3: 7-Pin Signal Segment

## Installing an Operating System

You can use a disk formatting and partitioning utility to format the Xcel-10 like any standard hard disk drive. Once formatted, you can install any operating system that is compatible with SATA devices. Because the method for installing a specific operating system may vary, SMART recommends you consult the operating system or SATA controller documentation for instructions.

## Troubleshooting

Table 4 lists some common problems and possible solutions. For more information, visit the SMART web site at [www.smartm.com/support](http://www.smartm.com/support), send an e-mail to [fre-techsupport-phx@smartm.com](mailto:fre-techsupport-phx@smartm.com), or contact technical support at 602-735-0300 in the U.S.

## Warranty

SMART Modular Technologies warrants this product to be free from defects in materials and workmanship for the duration of the warranty period. If this product fails within the warranty period due to such a defect, SMART will repair or replace this product.

This warranty does not apply if this product has been damaged by abuse, accident, disaster, misuse or incorrect installation. There are no user-serviceable components within the Xcel-10.

Problem	Possible Solution
The host computer does not recognize the Xcel-10.	Make sure the SATA cables are seated and in good condition.
	Check the system BIOS settings for SATA devices. See the manufacturer's manual for information on BIOS settings.
The operating system does not recognize the Xcel-10.	Check the host controller drivers. A SATA host controller and an appropriate software configuration are required for communicating with the Xcel-10.

Table 4: Troubleshooting

## Notice

This manual describes the features of the Xcel-10 drive. SMART Modular Technologies reserves the right to modify, amend, or in any way change the contents and/or products described herein, at any time, without notification.

The information contained in this document is provided for reference only. SMART Modular Technologies does not assume any liability arising out of the application or use of the products described herein. This document may contain or reference information or products protected by copyrights or patents and does not convey any license under the patent rights of SMART Modular Technologies, nor the rights of others.



### SMART Modular Technologies SSD Design Center

4415 E. Cotton Center Blvd.  
Phoenix, AZ 85040  
Tel: U.S. 602-735-0300  
Fax: U.S. 602-735-0349  
<http://www.smartm.com>